

ICITEE 2018

by Bayu Utomo

Submission date: 27-Sep-2022 09:21AM (UTC-0400)

Submission ID: 1910356592

File name: Bayu_Tri_Utomo_2018.pdf (2.4M)

Word count: 2763

Character count: 14364

The Placement of the Transmission Lightning Arrester (TLA) at 150 kV Network using Fuzzy Logic

¹⁴ Bayu Tri Utomo
 Department of Electrical Engineering, Faculty of Engineering,
 Hasanuddin University, Gowa 92119, Indonesia
 Email: bayutriutomo@gmail.com

¹⁴ Sri Mawar Said
 Department of Electrical Engineering, Faculty of Engineering,
 Hasanuddin University, Gowa 92119, Indonesia
 Email: srimawarsaid@yahoo.com

Muhammad Bachtiar Nappu
 Centre for Research and Development on Energy and Electricity,
² Hasanuddin University, Makassar 90245, Indonesia
² Department of Electrical Engineering, Faculty of Engineering,
 Hasanuddin University, Gowa 92119, Indonesia
 Email: bachtiar@eng.unhas.ac.id, thiar@engineer.com

Ardiaty Arief
 Centre for Research and Development on Energy and Electricity,
² Hasanuddin University, Makassar 90245, Indonesia
² Department of Electrical Engineering, Faculty of Engineering,
 Hasanuddin University, Gowa 92119, Indonesia
 Email: ardiaty@eng.unhas.ac.id, ardiaty@engineer.com

²¹ **Abstract**— Lightning is one of the main considerations in the causes of the high voltage network's overhead lines failure. The lightning even also become one of the most dangerous event on the transmission system. The placement of the Transmission Lightning Arresters (TLAs) is employed for optimizing the location of protection equipment, reducing the cost of installation and identifying the risk of failure. This paper uses fuzzy logic to get the optimal placement location for Transmission Lightning Arresters (TLAs) and the model for transmission tower were simulated on a 150 kV high voltage network in the Maros-Sungguminasa. The simulation results confirm the optimal placement of the Transmission Lightning Arresters (TLAs) in the system.

Keywords — Transmission Line Surge Arresters (TLAs), Fuzzy Logic, High Voltage Network 150 kV.

I. INTRODUCTION

Indonesian National Electricity Company or in Indonesian we called PT. PLN (Persero) is a state electricity company that plan, design, operate, and perform maintenance for any obstruction at the high voltage network in Indonesia. The company guarantees the operation of the system and providing the best quality to consumers [1].

In 2016, lightning strike incident occurred at the 150 kV overhead transmission line between Maros-Sungguminasa at the Southern Sulawesi power system and caused blackout. [2]. The detailed of the Southern Sulawesi power system can be seen in [3][4][5]. Protection against the lightning strike can be done by putting a Transmission Lightning Arresters (TLAs) [6], to avoid potential of instability and load shedding [7].

There have been several previous studies that discussed about the placement of TLAs. Many methodology developed for TLAs' placement optimization were using lightning location system [8][9][10], combined Neural Network (NN) and Genetic Algorithms (GA) [11]. Efficiency of surge arrester was assessed in a one or two phases of Brazilian transmission network by

using ATP in reference [12], surge arrester location was determined by using fuzzy logic techniques, but the study was implemented in the distribution network and the location of arrester was in node between cables, not at the transmission network and more specifically at the transmission tower. The TLA placement is important, especially considering as many power systems now are working at their stability limit and potential of congestion problems [13] [14] [15]. This paper designed placement of TLAs by using fuzzy logic that consider elevation, ground resistance, and flash density with the 150 kV high voltage network between Maros-Sungguminasa case study. The results also compare the induced voltage from lightning with and without TLAs.

²⁴ The structure of this paper is as follow. Section II informs the description about line data (systems) details, Section III explains about optimal placement TLAs. Section IV gives description about simulation without and with TLAs. The results of the simulation optimization of placement of TLAs is explained in Section V. Section VI concludes the main finding of this research.

II. SYSTEM DETAILS

A. Line Details

The overhead line of 150 kV Maros-Sungguminasa transmission line details are shown in Table I. The Maros - Sungguminasa 150 kV transmission line consist of 142 towers with total length of 48.48 km [2].

TABLE I. MAROS-SUNGGUMINASA LINE DATA [2]

Line Name	Total Tower	Length
From Line Maros	142	48.48 km
To Line Sungguminasa		

B. Geographical Profile

Fig.1 shows the coordinate of the Maros-Sungguminasa, while Fig.2 describes the elevation of 150 kV lines tower which was generated by using the data from PT. PLN (Persero) [2].



Fig. 1. Geographical Profile of Tower 150 kV Lines [2]

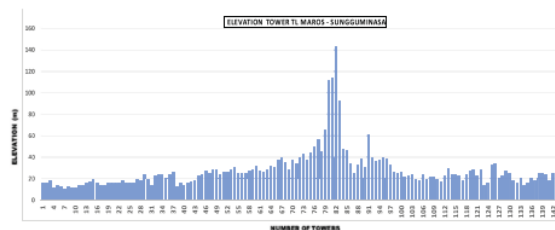

Fig. 2. Elevation of 150 kV Lines Tower

C. Lightning Flash Density

The rate of lightning flash density obtained from the Gowa Geophysics Station data is 106-126 flashes per sequence km/year as cited in [2]. Fig. 3 shows the map of Lightning Flash Density line.

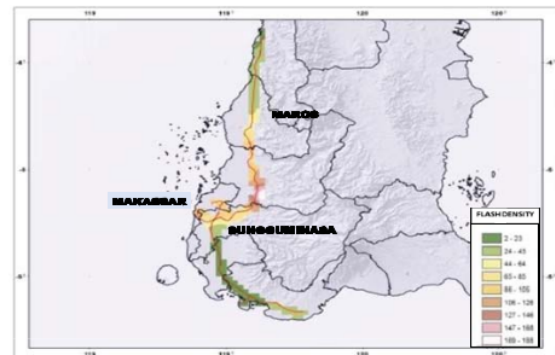

Fig. 3. Map of Lightning Flash Density [2]

The lightning flash density, elevation and the resistance of tower resistances are showed in Fig. 4. The towers with high rates of elevation flash density and ground resistance tends have high probability to be stroke by lightning.

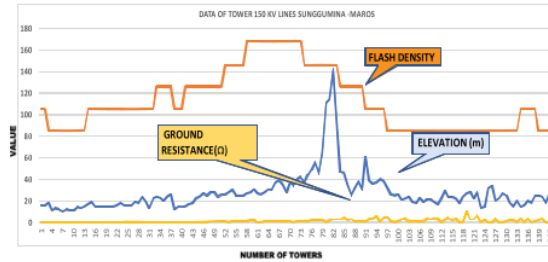

Fig. 4. Tower data elevation, ground resistance, and flash density.

D. Placement of TLAs Flowchart

The flowchart of the proposed placement of TLAs can be seen in Fig. 5. The fuzzy logic is designed based on data elevation, ground resistance, and flash density to formulated the membership and fuzzy rule base.

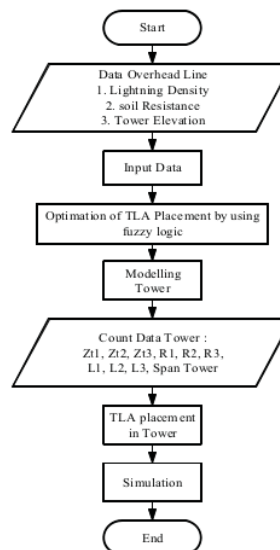

Fig. 5. Placement of TLAs Flowchart.

III. PLACEMENT OF TLAS BY USING FUZZY LOGIC

A. Fuzzy Logic

Fuzzy Logic is one of the artificial intelligence which is one of the most powerful control methods. It is known by multi-based resolution and multivariable considerations. Hence, fuzzy logic method has been used as a management tool for the most present system problems. The placement of TLAs was designed by using the Fuzzy logic Toolbox [16], which allowed the representation of power network protection using the arresters. and led to a location for placement of arresters [17]. In this paper, 142 tower data were used to generate the fuzzy memberships and rules to obtain the number of tower that for optimal Transmission Lightning Surge Arresters (TLAs) placement.

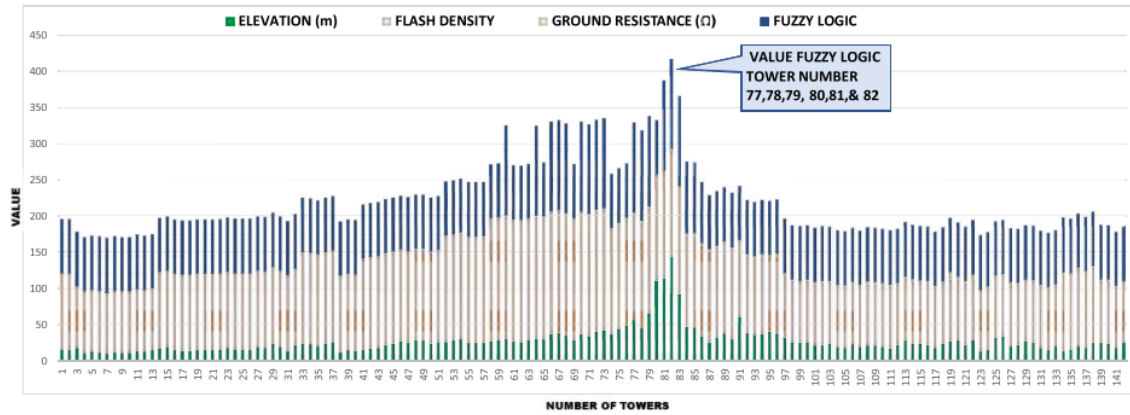

Fig. 6. Fuzzy Logic Result

Fig. 6 informs the fuzzyfication results as the combination of elevation, flash density, and ground resistances. From this optimization results, there are 6 towers that have the highest value which are Tower 77, Tower 78, Tower 79, Tower 81, Tower 82 and Tower 83 that are recommended for TLA placement.

IV. SIMULATION OF TRANSMISSION LIGHTNING SURGE ARRESTER (TLAS)

After obtaining the position of TLAs, the conditions of the 150 kV transmission line Maros – Sungguminasa were tested for two conditions, before and after the TLAs placement.

A. Modelling of Transmission System

There are several different transmission tower model proposed by research in the last few years [18]. Multistory tower designed by Masaru Ishii in 1991 [19] as shown in Fig. 7. Another model of multilevel tower is based on the high-voltage transmission line [20] [21][22]. In addition, a model of Takamitsu were introduced in a 12-nple distribution channels which are reasonably sufficient to represent a model of low voltage transmission line [23].

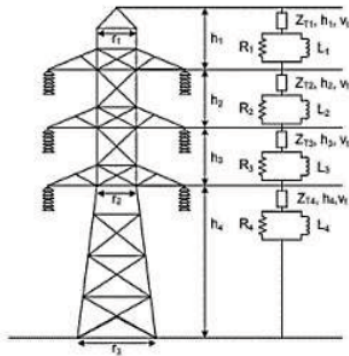

Fig. 7. Model Multistory

In this study the 150 kV transmission tower was modeled using model data and each story tower components are shown in Table II. Calculation formulas to compute each story components were using multistory model [24]. The formula is given by following form:

$$Z_{Ti} = 60 \left\{ \ln \left(\frac{H}{R} \right) - 1 \right\} \quad (1)$$

$$R = \frac{(R_1 L_2 + r_2 H + r_3 L_1)}{2H} \quad (2)$$

$$R_i = \frac{-2 * Z_{Ti} * \ln \sqrt{y}}{h_1 + h_2 + h_3} * h_i \quad (i = 1 - 3) \quad (3)$$

$$R_4 = -2 * Z_{T4} * \ln \sqrt{y} \quad (4)$$

$$L_i = R_i * \frac{2H}{v} \quad (i = 1 - 4) \quad (5)$$

$$H = h_1 + h_2 + h_3 + h_4 \quad (6)$$

Where

- Z_{Ti} = Impedance value for each segment of surge tower [Ω]
- H = high of tower [m]
- R = equivalent radius from tower [m]
- r_1 = the radius of the cone shape for the top of the tower [m]
- r_2 = radius of the cone to form the central part of tower [m]
- r_3 = the radius of the cone shape for the base of the tower [m]
- l_1 - the height of the base of the tower up to the middle [m]
- l_2 = the height of the central tower up to the peak tower [m]
- y = coefficient attenuation
- L_1 = value of inductance for each segment of the tower [μH]
- h_i - height for each segment of the tower [m]
- v = the speed of propagation [m/ μs]

B. Transmission Lightning Surge Arrester (TLAs)

Transmission lightning arresters (TLAs) provides protection for transmission and electrical equipment [25][26][27]. TLAs act to limit this voltage level by avoiding damage to protected equipment [28]. There are three models of arrester. Two models of arrester are the Pinceti and Giannettoni [29] model and the Fernandez and Diaz model [30].

TABLE II. MULTYSTORY MODEL DATA OF 150 KV TOWER

No	Parameters	Number of Tower						
		77	78	79	80	81	82	83
1	Zt1 (Ω)	190	190	190	190	190	190	190
2	Zt2 (Ω)	190	190	190	190	190	190	190
3	Zt3 (Ω)	190	190	190	190	190	190	190
4	Zt4 (Ω)	190	190	190	190	190	190	190
5	R1 (Ω)	14.1	14.1	14.1	14.1	14.1	14.1	14.1
6	R2 (Ω)	14.1	14.1	14.1	14.1	14.1	14.1	14.1
7	R3 (Ω)	14.1	14.1	14.1	14.1	14.1	14.1	14.1
8	R4 (Ω)	42.4	42.4	42.4	42.4	42.4	42.4	42.4
9	L1 (uH)	2.7	2.7	2.7	2.7	2.7	2.7	2.7
10	L2 (uH)	2.7	2.7	2.7	2.7	2.7	2.7	2.7
11	L3 (uH)	2.7	2.7	2.7	2.7	2.7	2.7	2.7
12	L4 (uH)	8	8	8	8	8	8	8
13	Rf (Ω)	2.3	2.3	2.3	0.4	2.2	2.9	2.8
14	Span (m)	492	252	322	289	238	274	375

In this study, the equivalent model of arrester used is the model proposed by the IEEE Working Group 3.4.11 [31] that has two components known as the A0 and A1 (varistor) divided by R1-L1 filters. Parallel inductance L0 used to increase

stability. A0 have a higher voltage than the A1 as shown in Fig. 8 [31]. The parameter for TLAs is given in Table III.

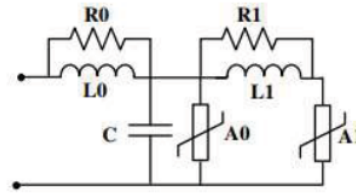

Fig. 8. IEEE Frequency Dependent Model. [18]

TABLE III. PARAMETER TRANSMISSION LIGHTNING SURGE ARRESTER (TLAs) [18]

Parameter	Arrester IEEE Model
R0	25.43 (Ω)
R1	17.85 (Ω)
L0	0.278 (uH)
L1	1.017 (uH)
C	967.21 (pF)

V. RESULTS OF TRANSMISSION LIGHTNING SURGE ARRESTERS(TLAs) PLACEMENT

After attaining the most optimum TLA placement by using fuzzy logic, then it was simulated to assess the results. For the first condition, we simulated without TLA for Tower 77 to Tower 82 as shown by Fig. 9, where the transmission line that connects the Maros Substation to Sungguminasa Substation and the lightning strike the transmission network. For the second condition, given the TLAs using IEEE Arrester Model for Tower 77 to Tower 82 is shown by Fig. 10, with transmission line that connects the Maros Substation to Sungguminasa Substation.

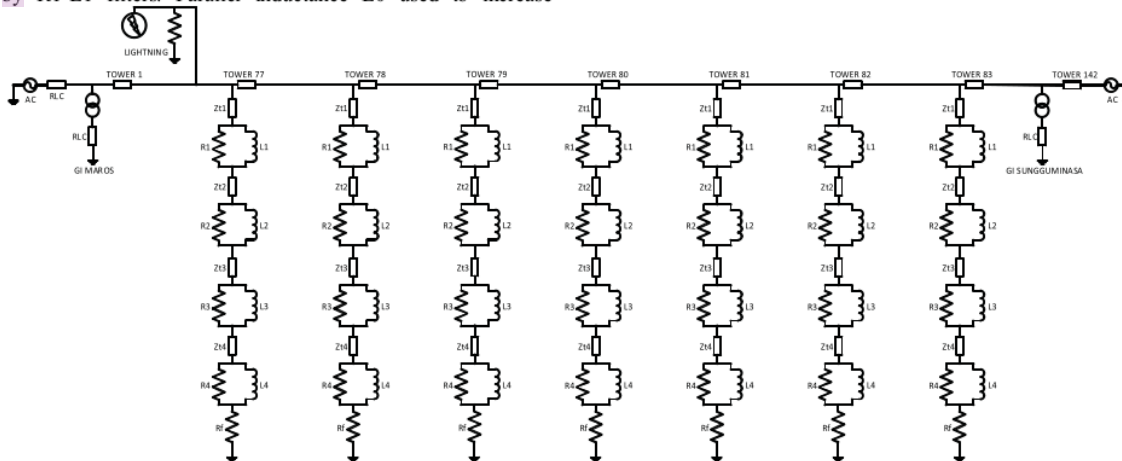

Fig. 9. Modelling of Multistory Tower without TLAs

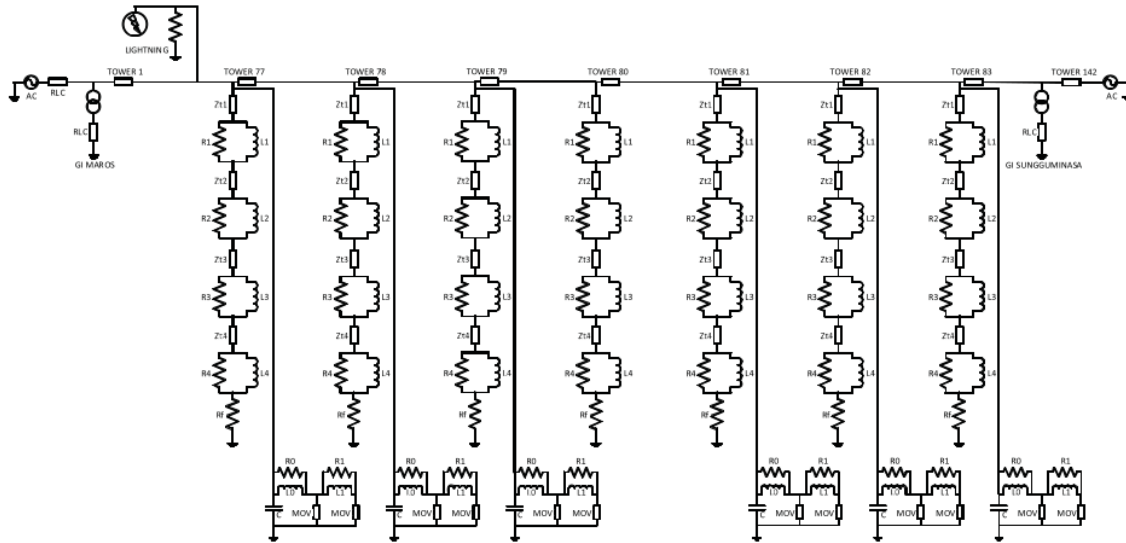

Fig. 10. Modelling of Multistory Tower with 6 TLAs

From the simulation results show that TLAs placement can reduce the effect of lightning to the tower. Fig. 11 shows voltage after lightning of the system without TLAs it can be seen, after lightning strike the induced voltage raise to almost 2 MV in 0.005 ms. Where Fig.12 shows the voltage dynamic after lightning with TLAs. As the results, the TLAs can reduced the induced voltage to approximately 1.7 MV in 0.005 ms.

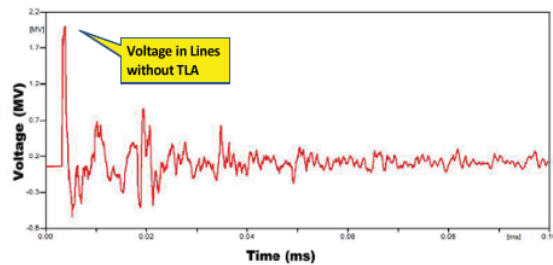

Fig. 11. Result without TLAs placement

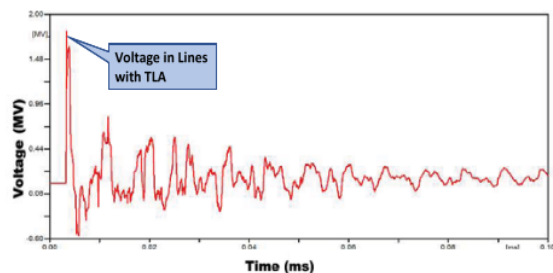

Fig. 12. Result TLAs placement

VI. CONCLUSIONS

In the year 2016, there was lightning disturbance in the electrical system of the Southern Sulawesi power system. The lightning stroke the 150 kV overhead lines between Maros and Sungguminasa that led to the interruption of electricity. There are as many as 142 towers connecting the 150 kV overhead lines 150 kV between Maros Substation to Sungguminasa Substation. This paper simulated lightning protection by installing a Transmission Lightning Arresters (TLAs) at the tower. The effective installation of TLAs is needed for its placement optimization.

This paper uses fuzzy logic to observe the point of optimal placement in the overhead line of 150 kV Maros- Sungguminasa. And the results confirm that there are 6 point of towers which have the most optimal value among all the 142 point towers. The towers are Tower 77, 78, 79, 81, 82 and Tower 83. After getting optimal placement of the tower, then the overhead line of 150 kV Maros-Sungguminasa was modelled with and without TLAs. The TLAs model used was a model proposed by IEEE Working Group 3.4.11. The results of the simulation for before and after the placement of TLA showed a decrease in voltage after the placement of TLAs.

REFERENCES

- [1] M. Rawi, M. Z. A. A. Kadir, and N. Azis, "Lightning study and experience on the first 500kV transmission line arrester in Malaysia," in *2014 International Conference on Lightning Protection (ICLP)*, 2014, pp. 1106-1109.
- [2] P. P. (Persero) W. Sulselbar, "Kajian Penentuan Titik Pemasangan Transmission Line Arrester (TLA) Jalur Backbone Maros – Sungguminasa Untuk Menurunkan Gangguan Transmisi Akibat Petir Di UPT Sulselbarab," Sulawesi Selatan, Makassar, 2017.
- [3] A. Arief, M. B. Nappu, S. M. Rachman, and M. Darusman, "Optimal photovoltaic placement at the southern sulawesi

- power system for stability improvement," in **13** *2017 4th International Conference on Information Technology, Computer, and Electrical Engineering (ICITACEE)*, 2017, pp. 87–92.
- [4] M. B. Nappu, M. I. Bachtiar, and A. Arief, "Network **126**s reduction due to new hydro power plant integration," in *2016 3rd International Conference on Information Technology, Computer, and Electrical Engineering (ICITACEE)*, 2016, pp. 181–185.
- [5] **5** Arief and M. B. Nappu, "Voltage drop simulation at Southern Sulawesi power system considering composite load model," in *2016 3rd International Conference on Information Technology, Computer, and Electrical Engineering (ICITACEE)*, 2016, pp. 169–172.
- [6] R. Zoro and R. Mefiardhi, "Insulator Damages due to Lightning Strik**15** in Power System: Some Experiences in Indonesia," in *2006 IEEE 8th International Conference on Properties & applications of Dielectric Materials*, 2006, pp. 677–682.
- [7] **31** Arief, Z. Dong, M. B. Nappu, and M. Gallagher, "Under voltage load shedding in power systems **29** wind turbine-driven doubly fed induction generators," *Electr. Power Syst. Res.*, vol. 96, pp. 91–100, 2013.
- [8] V. Milardić, I. Uglešić, and A. Xemard, *Optimal Line Surge Arresters Installation Using Lightning Location System*, vol. **11** 012.
- [9] E. Perez, A. Delgado, D. Urrutia, and H. Torres, "Optimizing the surge arresters location for improving lightning induced voltage performance of distribution network," in *Power Engineering Society General Meeting, 2007. IEEE*, 2007, pp. 1–6.
- [10] **28** Shariatinasab, B. Vahidi, and S. H. Hosseinian, "Statistical evaluation of lightning-related failures for the optimal **17** location of surge arresters on the power networks," *IET Gener. Transm. Distrib.*, vol. 3, no. 2, pp. 129–144, 2009.
- [11] V. B., T. M. R. Bank, and H. S. H., "Determining arresters best positions in power system for lightning shielding fa**27** protection using simulation optimization approach," *Eur. Trans. Electr. Power*, vol. 20, no. 3, pp. 255–276, Dec. 2008.
- [12] R. Alipio, M. H. R. Duarte, J. C. A. Dias, and A. S. De **30** anda, "Lightning performance of transmission lines partially protected by st**18** arresters considering typical Brazilian conditions," in *2017 International Symposium on Lightning Protection (XIV SIPDA)*, 2017, pp. 365–369.
- [13] **3** B. Nappu, A. Arief, and R. C. Bansal, "Transmission management for congested power system: A review of concepts, technical challenges and development of a new methodology," *Renew. Sustain. Energy Rev.*, vol. 38, pp. 572–580, 2014.
- [14] M. B. Nappu, R. C. Bansa**3** and T. K. Saha, "Market power implication on congested power system: A case study of financial withheld strategy," *Int. J. Electr. Power Energy Syst.*, vol. 47, pp. 408–415, 2013.
- [15] M. B. Nappu and A. Arief, "Network Losses-Based Economic Redispatch for Optimal Energy Pricing in a Congested Power System," *Energy Procedia*, vol. 100, pp. 311–314, 2016.
- [16] J. S. R. Jang, *MATLAB: Fuzzy logic toolbox user's guide: Version 1*. Math Works, 1997.
- [17] A. L. Orille, S. Bogarra, M. A. Grau, and J. Iglesias, "Lightning protection of power systems using fuzzy logic techniques," in *Fuzzy Systems, 2003. FUZZ'03. The 12th IEEE International Conference on*, 2003, vol. 2, pp. 1406–1411.
- [18] M. Z. Islam, M. R. Rashed, and M. S. U. Yusuf, "ATP-EMTP modeling and performance test of different type **4** lightning arrester on 132kv overhead transmission tower," in *2017 3rd International Conference on Electrical Information and Communication Technology (EICT)*, 2017, pp. 1–6.
- [19] M. Ishii *et al.*, "Multistory transmission tower model for **12** tning surge analysis," *IEEE Trans. Power Deliv.*, vol. 6, no. 3, pp. 1327–1335, 1991.
- [20] **8** Hara and O. Yamamoto, "Modelling of a transmission tower for lightning-surge analysis," *IEE Proceedings-Generation, Transm. Distrib.*, vol. 143, no. 3, pp. 283–289, 1996.
- [21] L. A. Martinez and F. Castro-Aranda, "Model **19** overhead transmission lines for line arrester studies," in *IEEE Power Engineering Society General Meeting, 2004.*, 2004, p. 1125–1130 Vol.1.
- [22] **10** Zawani, Junainah, Imran, and M. Faizuhar, "Modelling of 132kV Overhead Transmission Lines by us**10** ATP/EMTP for Shielding Failure Pattern Recognition," *Procedia Eng.*, vol. 53, pp. 278–287, 2013.
- [23] T. Ito, T. Ueda, H. Watanabe, T. Funabashi, and A. Ametani, "Lightning flashovers on 77-kV systems: observed voltage bias effects and analysis," *IEEE Trans. Power Deliv.*, vol. 18, no. 2, pp. 545–550, 2003.
- [24] A. A. Kusuma, P. A. A. Pramana, B. S. Munir, and S. R. Ayu, "Studying of lightning surge transient effect on 500 kV quadruple circuit transmission line," in *2016 6th International Annual Engineering Seminar (InAES)*, 2016, pp. 276–279.
- [25] H. Seyedi, M. Sanaye-Pasand, and M. R. Dadashzadeh, "Application of transmission line surge arresters to reduce switching overvoltages," in *International Conference on Power Systems Transients (IPST'05)*, 2005.
- [26] S. Furukawa, O. Usuda, T. Isozaki, and T. Irie, "Development and applications of lightning arresters for transmission lines," *IEEE Trans. Power Deliv.*, vol. 4, no. 4, pp. 2121–2129, 1989.
- [27] E. J. Tarasiewicz, F. Rimmer, and A. S. Morched, "Transmission line arrester energy, cost, and risk of failure analysis for partially shielded transmission lines," *IEEE Trans. Power Deliv.*, vol. 15, no. 3, pp. 919–924, 2000.
- [28] E. T. W. Neto, E. G. Da Costa, and M. J. A. Maia, "Artificial neural networks used for ZnO arresters diagnosis," *IEEE Trans. Power Deliv.*, vol. 24, no. 3, pp. 1390–1395, 2009.
- [29] P. Pinceti and M. Giannettoni, "A simplified model for zinc oxide surge arresters," *IEEE Trans. power Deliv.*, vol. 14, no. 2, pp. 393–398, 1999.
- [30] F. Fernandez and R. Diaz, "Metal oxide surge arrester model for fast transient simulations," in *The Int. Conf. on Power System Transients IPAT*, 2001, vol. 1.
- [31] IEEE Working Group 3.4.11, "Modeling of metal oxide surge arresters," *IEEE Trans. Power Deliv.*, vol. 7, no. 1, pp. 302–309, 1992.

ORIGINALITY REPORT

18%

SIMILARITY INDEX

13%

INTERNET SOURCES

14%

PUBLICATIONS

8%

STUDENT PAPERS

PRIMARY SOURCES

1	ieeexplore.ieee.org Internet Source	2%
2	Submitted to School of Business and Management ITB Student Paper	1%
3	www.mdpi.com Internet Source	1%
4	repository.kpi.kharkov.ua Internet Source	1%
5	Submitted to Singapore Institute of Technology Student Paper	1%
6	iclp2020.org Internet Source	1%
7	Submitted to Montana State University, Bozeman Student Paper	1%
8	M. T. Chen. "Lightning transient simulation and analysis of EGLA under single-ended circuit breaker open system", 2011 7th Asia-	1%

9

Md. Zoyheroul Islam, Md. Rasheduzzaman Rashed, Md. Salah Uddin Yusuf. "ATP-EMTP modeling and performance test of different type lightning arrester on 132kv overhead transmission tower", 2017 3rd International Conference on Electrical Information and Communication Technology (EICT), 2017

Publication

1 %

10

S.N.M. Arshad, N.S. Tajudin, N.H. Halim, A.Z. Abdullah, C.L. Wooi, Nuriziani Hussin. "Simulation on Lightning Effects to 132 kV Underground Cable by using Alternative Transients Program / Electromagnetic Transients Program (ATP/EMTP)", 2018 IEEE 7th International Conference on Power and Energy (PECon), 2018

Publication

1 %

11

Khalil Gorgani Firouzjah. "Distribution Network Expansion Based on the Optimized Protective Distance of Surge Arresters", IEEE Transactions on Power Delivery, 2018

Publication

1 %

12

dspace.kuet.ac.bd
Internet Source

1 %

13	Internet Source	1 %
14	Ramadoni Syahputra, Imam Robandi, Mochamad Ashari. "Performance Improvement of Radial Distribution Network with Distributed Generation Integration Using Extended Particle Swarm Optimization Algorithm", International Review of Electrical Engineering (IREE), 2015 Publication	1 %
15	researchonline.gcu.ac.uk Internet Source	<1 %
16	Submitted to University of Technology, Sydney Student Paper	<1 %
17	cv.birjand.ac.ir Internet Source	<1 %
18	latamt.ieeer9.org Internet Source	<1 %
19	www.sciencepubco.com Internet Source	<1 %
20	archive.org Internet Source	<1 %
21	Eduard Bullich-Massague, Andreas Sumper, Roberto Villafafila-Robles, Joan Rull-Duran. "Optimization of Surge Arrester Locations in	<1 %

Overhead Distribution Networks", IEEE
Transactions on Power Delivery, 2015

Publication

22

Vita, V., A.D. Mitropoulou, L. Ekonomou, S. Panetsos, and I.A. Stathopoulos. "Comparison of metal-oxide surge arresters circuit models and implementation on high-voltage transmission lines of the Hellenic network", IET Generation Transmission & Distribution, 2010.

Publication

<1 %

23

www.crosbi.znanstvenici.hr

Internet Source

<1 %

24

www.ipstconf.org

Internet Source

<1 %

25

www.sigma-not.pl

Internet Source

<1 %

26

etd.repository.ugm.ac.id

Internet Source

<1 %

27

pure.manchester.ac.uk

Internet Source

<1 %

28

tjee.tabrizu.ac.ir

Internet Source

<1 %

29

vbn.aau.dk

Internet Source

<1 %

30

Felipe De Vasconcellos, Rafael Alipio, Fernando Moreira. "Evaluation of the Lightning Performance of Transmission Lines Partially Protected by Surge Arresters Considering the Frequency-Dependent Behavior of Grounding", IEEE Latin America Transactions, 2022

Publication

<1 %

31

Pouya Pourghasem, Heresh Seyedi. "An under-voltage load shedding scheme to prevent voltage collapse in a microgrid", 2019 International Conference on Protection and Automation of Power System (IPAPS), 2019

Publication

<1 %

Exclude quotes On

Exclude matches < 5 words

Exclude bibliography On